

IRDHT PLUS

Infra Red Drying High Temperature system for spray booths



PAINTSHOP EQUIPMENT



CA DIF

IRDHT PLUS

THE COMPLETE CURING SYSTEM FOR THE SPRAYBOOTH

IRD PLUS enables the latest generation 'super high solid' paints to dry quickly and efficiently compared to traditional methods. Thermal energy is generated by innovative radiating panels. The panels are electrically powered and incorporate leading edge technology to ensure maximum radiation efficiency.

IRDHT PLUS makes the burner and central heating system redundant! IRD wall panels can reach a maximum operating temperature of 130°C, whilst the HT PLUS panels, installed on the ceiling of the spray booth, can reach a maximum temperature of 350°C enabling the ideal temperature to be achieved on the vehicle. The combination of the two technologies produces a system of far greater efficiency than

traditional gas/oil burners, and vastly reduces your carbon footprint.

Benefits:

- Improved drying quality using diffused infrared rays
- Reduction in running costs
- Reduction in painting times
- Reduction in curing times
- Can be installed in any existing spray booth
- Existing central heating system becomes redundant
- Environmentally friendly
- Reduces your carbon footprint



Quality and safety: certifications

Cadif systems and radiating panels are in compliance with directive with the ATEX 94/9/EC Directive.

Installation

IRDHT PLUS is typically installed in one day on average (subject to site survey). Once the installation has been completed the system is tested and is ready for use.

Training

No specific training is required to operate the system, and it does not change your existing practices. IRDHT PLUS is very simple and user-friendly.

Our installation engineers will provide you with all necessary instructions on how to use and program the system.



FAST PAINTING WITH A QUICKER FLASH-OFF

The operating cycle

The operating cycle involves a number of phases:

Preheating

The surfaces to be painted can be preheated by placing the vehicle or the parts to be painted inside the booth, then switching the IRDHT PLUS panels on without the need for forced ventilation.

Painting

After preheat you can start the painting phase. Painting takes place using forced ventilation with cold air. Environmental comfort is guaranteed by the fact that, although the entry air is cold, the heat radiated by the panels warms the air and the temperature of the vehicle remains unchanged. Using the intelligent monitoring systems supplied with the IRD system the temperature of the panels is regulated to maintain the ambient air temperature for optimal painting.

Temperature adjustment

Temperatures can be adjusted according to the external air temperature and the particular paint product used – see manufacturers recommendations. Flash-off of the base coat takes place very quickly and with the use of the IRD radiation panels the water molecules are excited which assists evaporation.

Drying

Drying takes place without the use of forced ventilation. Radiating panels are brought up to their maximum temperature which heats the vehicle and the air inside the booth, enabling the paint to actually 'bake'.

Timed ventilation during drying

During this phase solvents continue to evaporate. To prevent the solvents from reaching abnormally high concentrations the forced ventilation system automatically operates every 10–15 minutes with the air inside the booth being totally renewed after a few seconds.

Cooling

Once the drying cycle has been completed, normally 25 to 30 minutes – subject to paint specification, the panels are switched off and the booth is cooled. Cooling takes place with forced ventilation for 5 minutes managed automatically from the electrical panel.

Temperature variations.



ENERGY SAVINGS AND COST REDUCTIONS

Energy benefit

The CADIF technology allows heat to be transmitted directly from the panels to the vehicle without the usual losses expected when using hot air systems. This results in energy benefits and consideration for the environment, due to the de-commissioning of the gas/oil heating system.

The IRDHT PLUS system uses 25kW of power on average, approximately 7–10 times less thermal power than the burner in a conventional oven. This process offers very significant energy savings and allows you to work in a more eco-friendly manner as the burner is no longer needed. In terms of costs, the savings are just as significant given that an operating cycle (preheating, painting and curing) uses 25kWh on average. There are considerable cost savings when using just 25kWh of electricity compared to the fuel (oil or gas) required to operate a 200–300 kW burner.

Power and heating control

A major benefit of our technology is being able to adjust the power and the temperature of body panels, and thus the temperature of the areas to be painted and cured. Other products using infrared technology only allow switching on or off, however the IRDHT PLUS system offers continuously variable adjustment.

More importantly the IRDHT PLUS system can be operated in separate zones – four areas: right side, centre, left side and ceiling.

Greater productivity and customer satisfaction

IRDHT PLUS radiates heat by means of diffused infrared rays. In this manner, the paint is heated and cured from the inside out allowing solvents to escape, unlike the heating in conventional hot air booths which takes place via convection/conduction i.e. from the outside in, trapping solvents and resulting in longer curing times. During the preheating phase the car is brought to the temperature required in just a few minutes, whilst

during the painting phase it is maintained at 25°–30° depending on the manufacturer's specification. Radiation has a particular effect on water molecules, enabling them to evaporate more quickly compared to other forms of heat transmission. This enables us to speed up the flash-off of the base coat and thus the entire painting phase.

The quality of drying is very high as it takes place from the inside out, and once the panel area has cooled down you can continue with any polishing without problems; drying takes place in depth.

With IRDHT PLUS a painting and drying cycle can be achieved in less time than conventional systems, thus increasing your productivity and reducing the car delivery time to the customer.

An excellent investment

Once the IRDHT PLUS system is installed you can expect a return on your investment within three years, subject to a survey of your current fuel usage.

Each painting cycle with the IRDHT PLUS system will cost you approximately £2.00*, allowing you to save between £6 and £10 per cycle depending on the power of the existing burner and the type of fuel used. Based on the number of painting cycles carried out, the calculation is simple – assuming a purchase with an interest free loan from the Carbon Trust (subject to approval) repayment instalments could be less than current energy bills.

** based on power prices at October 2007.*

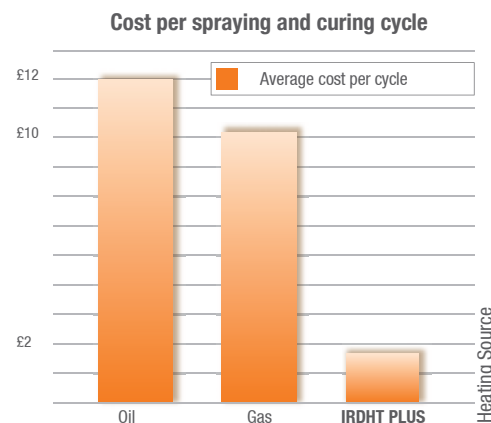

TECHNICAL DATA

IRD PANELS

The technical data below shows the structural features of the panels. All materials used are Class 0 self-extinguishing.



IRD 6502750 B technical data sheet

Radiating panel dimensions	650 x 2750 x 28
Electrical power	2.8 KW
Electrical power when running	2.5 KW
Colour	White
Max. surface temperature	130°C

Standard panel dimensions (mm)

390 x 1400	650 x 2750
390 x 2750	1050 x 2500
650 x 1400	980 x 2750
650 x 2250	980 x 1400



HT PANELS

The HT panels are 10 cm thick, offering minimal height reduction in the painting booth.

Finished in anodized-aluminium to match the oven plenum structure.

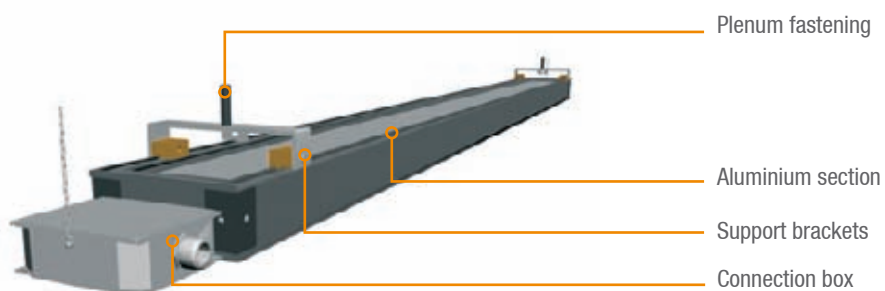

Technical data sheet of an HTPLUS system for 7m x 4m preparation area

No. 5 HT PLUS Panels	dim. 200 mm x 2700 mm, 3.0 kW each
Maximum instantly absorbed power	15 kW
Hourly cost at max. power	average 80 pence
Temperature reached in 3 min.	HT PLUS panels are set at a max. temperature of 350°C
Temperatures produced on vehicles	from 30 to 85°C

For any spraybooth – no additional space needed

The IRDHT PLUS system can be installed in any existing spraybooth. The IRD wall panels are available in 8 different sizes which ensure the right configuration can be achieved for any booth both in terms of dimensions and position (horizontal at the top at 45°, horizontal on the walls on one or two levels, vertical, mixed, etc.). The IRD panels are just 28 mm deep; this feature is essential to avoid compromising the dimensions of the booth. Available in white with anodised aluminium frames

to complement the spray booth's existing walls.

The HT PLUS panels are available in shapes and dimensions to fit any existing plenum. The small dimensions of the high temperature panels results in minimal effect on the air flow coming from the plenum. The design of the panels also means there are no surfaces where unwanted dust could build up.

IRD – HT Installation examples

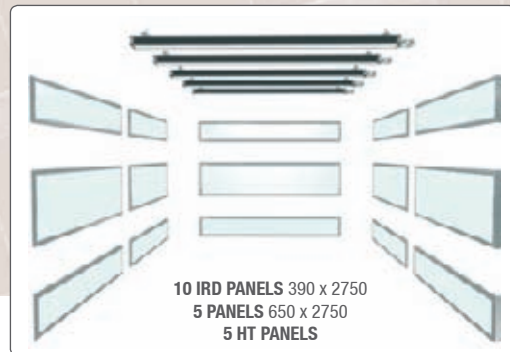
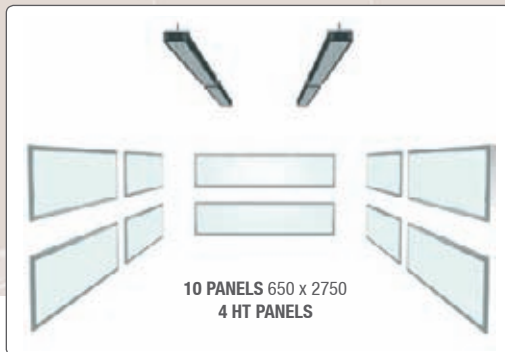
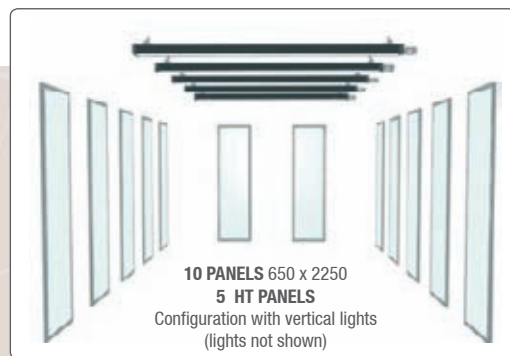
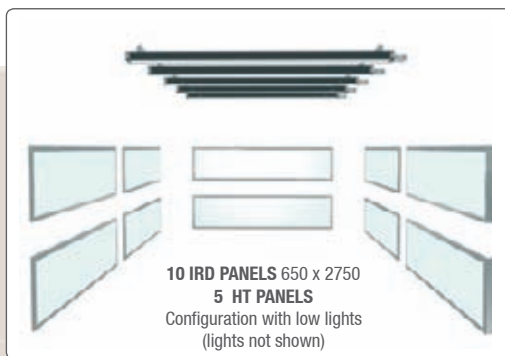

Distributor



Eco Repair Systems Ltd.

1 Saxon Road, Ashford, Middlesex, TW15 1QL

T: 01784 886288 M: 07834 620464

E: trevor@ecorepairsystems.co.uk

W: www.ecorepairsystems.co.uk

Contact us now for a full demonstration.